



*East of England*



*National Institute for  
Health Research*

Joint Health Research Conference:  
**Committed to better research in the NHS**

Friday 6 November 2009

Sopwell House, St Albans, Hertfordshire



# The East of England Approach to Research & Innovation

Dr Paul Cosford  
Regional Director of Public Health

# Overview

- Strategic Approach - Benefits of working together in an alliance of the NHS, academia, industry and enterprise
- Review achievements in stimulating research and innovation aimed at meeting NHS priorities and needs in one SHA in England
- Supporting the East of England Regional Vision – *Towards the Best Together*
- Consider future challenges arising from national policy



# East of England Health Research and Innovation Strategic Approach

Contribute to the **health, economic prosperity and sustainable development** of the East of England by increasing the **volume and quality** of research and innovation in health care and encouraging the **use of research and innovation** to improve health and health services

Through **collaborative working** between the NHS, academia, industry,



# East of England Health Research and Innovation Strategic Approach

- Development of a common strategic framework
- Build capacity for research & innovation
- Ensure research and innovation programmes respond to NHS priorities
- Use research evidence and new technologies to benefit clinical practice and patients quality of life



# Research & Innovation Cycle

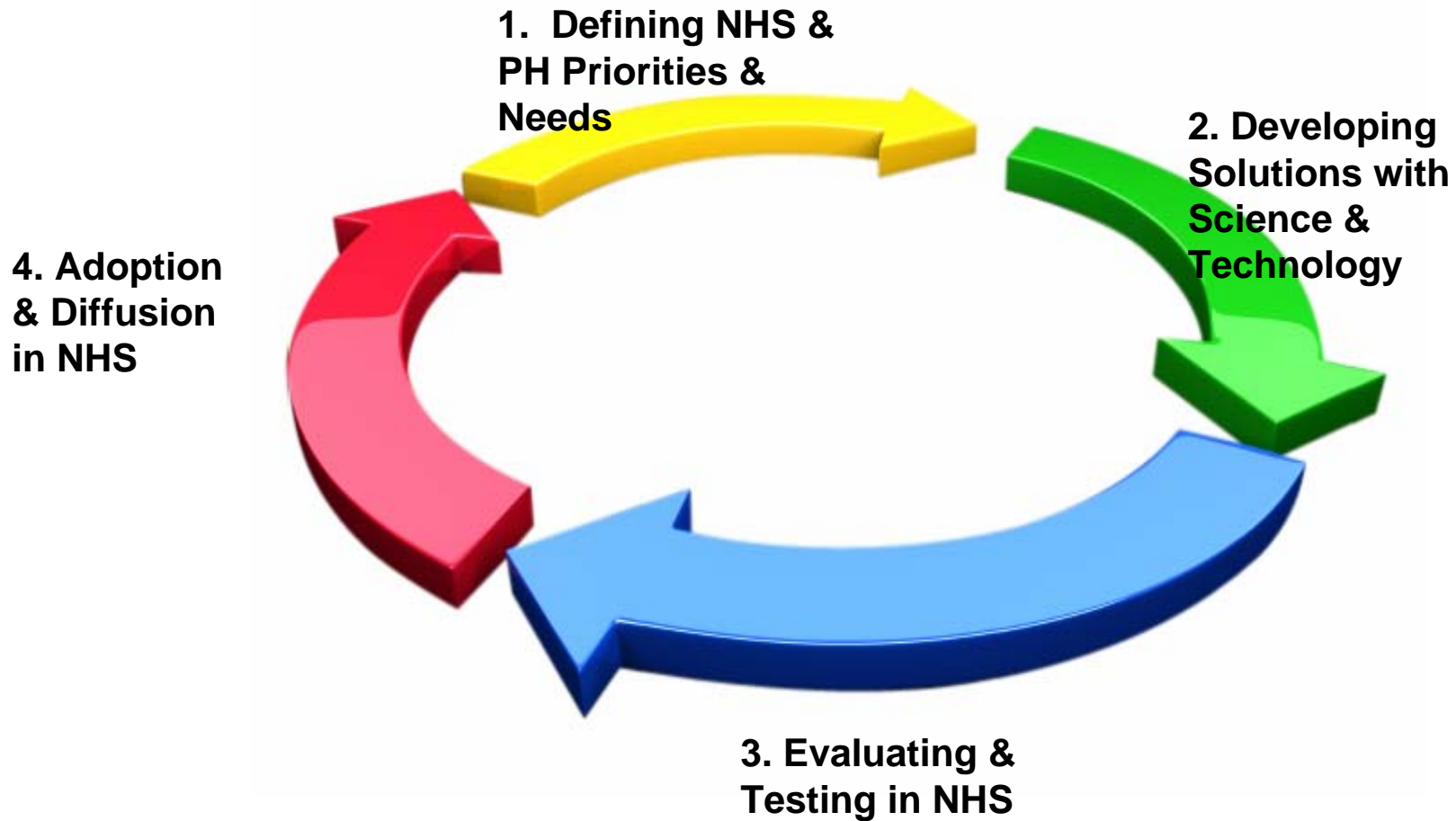

## Guide to the new landscape and its linkages

**PCT:** primary care trust  
**SHA:** strategic health authority  
**RDA:** regional development authority  
**CLAHRC:** collaborations for leadership in applied health research and care  
**HIC:** health innovation and education clusters  
**AHSC:** academic health science centres  
**BRC/BR:** biomedical research centres/units  
**Univ:** universities

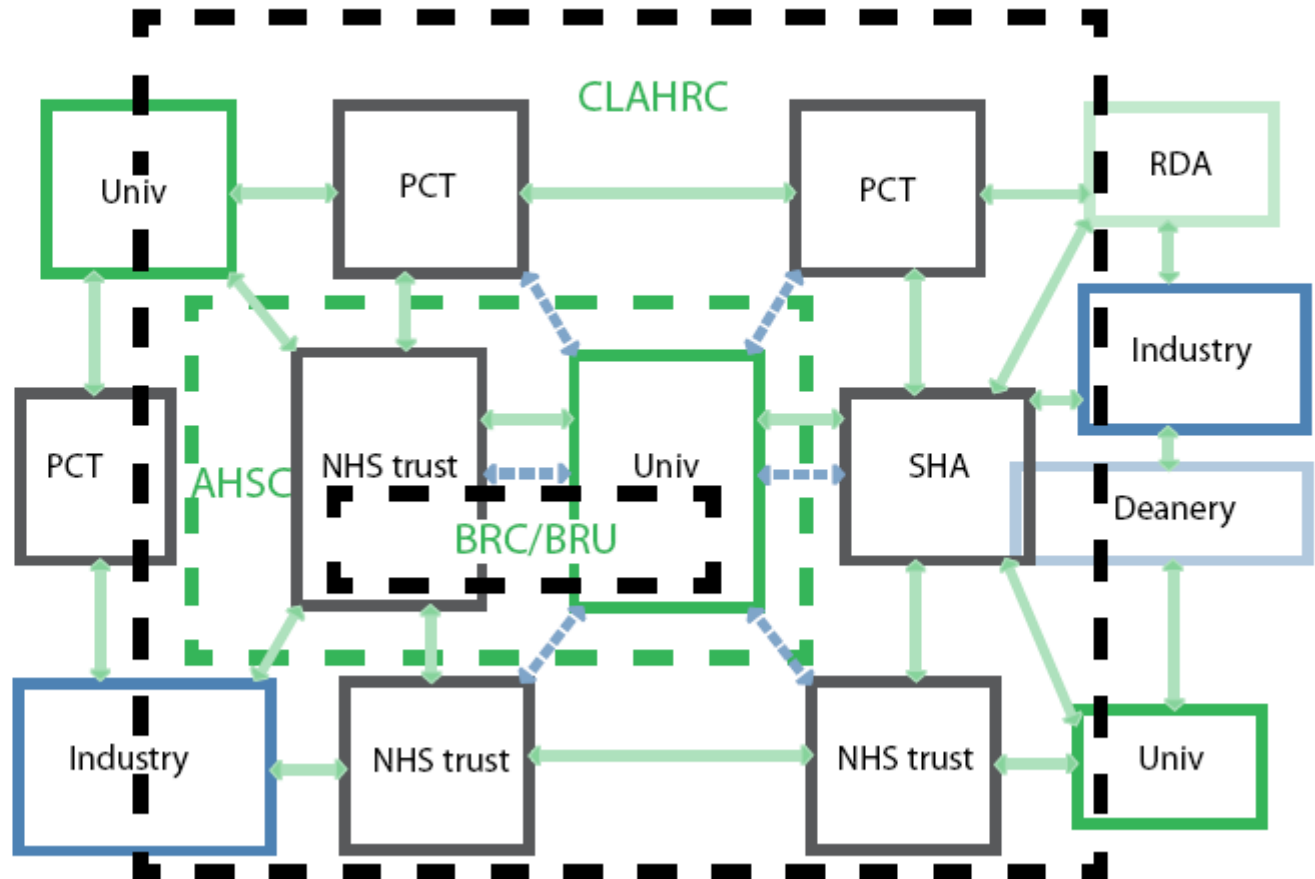

NHS Confederation Briefing Issue 5 “Making Sense of the new innovation landscape”

[http://www.nhsconfed.org/Publications/Documents/HSRN\\_briefing\\_innovation300409.pdf](http://www.nhsconfed.org/Publications/Documents/HSRN_briefing_innovation300409.pdf)

# Research and Innovation Pathway

**Identifying and Communicating Priorities & Needs**

**Development of Solutions**

**Testing of Solutions**

**Adoption And Diffusion**

**DH Priorities**

**Basic Research**

**Clinical Research**

**Review/ Policy Guidance**

**Regional Priorities TtBT**

**Innovation Design Testing Proof of Concept Intellectual Property**

**Innovation Testing**

**Procurement**

**NHS Unmet Need**

**Publications Licensing**

**Adoption Management /Clinical Utility**

Innovation Council  
 SBRI  
 SHA – CPB R  
 HEE Scouts

Universities  
 Industry  
 NHS  
 BRC

BRC  
 AHSC  
 RDS  
 CRNs  
 CLAHRC  
 HEE

Innovation Council  
 CLAHRC  
 HIECs  
 EAC  
 Commissioners  
 HEE Scouts



# Achievements 2006-09

- Coordinating Infrastructure Bids – CRNs,BRC,CLAHRC AHSC,HIECs
- Clinical Academic Workforce - MRES, PhD, Post-Doc and Fellowships
- Stimulating innovation and enterprise -Small Business Research Initiative
- Stimulating Research and Innovation to support Towards the Best Together
- NHS East of England Centre for Adoption of Evidence based Practice and Innovation



# Cambridge Academic Health Science Centre

- A new world leading academic-clinical partnership - one of five designated AHSCs – the University of Cambridge Health Partners
- The University was ranked first in the UK and second in the world for biomedical and life sciences in 2008
- The three Trusts in the partnership bring excellence in general and specialised services, internationally recognised cardiothoracic services, mental health and learning disability services
- Improving patient care, patient outcomes and population health, through innovation and the tripartite mission of integration of service delivery, health research and clinical education



# Collaboration for Leadership in Applied Health Research and Care

- Mental health research partnership led by Cambridge and Peterborough NHS Foundation Trust, one of 9 in England
- Focus on applied research, testing new treatments and new ways of working in specific clinical areas
- The Collaboration will help NHS staff to incorporate research findings into everyday working practices
- 5 year £23m centre started work on 1<sup>st</sup> October 2008



# Health Innovation & Education Clusters

- Partnerships between primary, secondary and tertiary care organisations – working across sectors & settings
- Purpose is to bring the benefits of research and innovation directly to patients
- Improving the health of local populations as well as improving care and clinical outcomes
- Strengthen the co-ordination of education and training to support excellence



# Government Scheme

## Small Business Research Initiative

- SBRI is a mechanism for bringing innovative solutions to government departments
- Enables procurement of new technologies faster and provides support for small companies
- DH Pilot: Technologies which address the specific needs identified, contribute to reducing the carbon output of healthcare and have the potential to make a measurable improvement to patient outcomes.



# Stimulate Innovation in NHS Priorities

## *Small Business Research Initiative - East*

- NHS East of England Pilot supported by the SHA, EEDA, NHS Innovation Hub and the TSB
- Managing Long Term Conditions, Keeping Children Active and Patient Safety.
- Funding in two phases: 6 month feasibility study and a further 2 year development phase, by which time proof of concept should be established.
- Phase 1 awards to be announced shortly



# Stimulate Research and Innovation to support *Towards the Best Together*

- 10 Clinical Programme Boards – academic members
- ESRC Research Fellow – ESRC, SDO and SHA
- Produce reviews of evidence in support of CPB interventions
- Develop research questions where gaps in evidence are identified
- Research Challenges Award Scheme



# Centre for the Appraisal and Adoption of Evidence-Based Practice and Innovation

- Collaboration between the SHA, PCTs, PH Libraries Network, NHS Innovation Hub, ERPHO, EEDA
- Aim is to contribute to improvements in patient care by providing a coordinated appraisal and adoption service for the East of England
- Mechanism for commissioners to increase adoption of evidence and innovation



# Centre for the Appraisal and Adoption of Evidence-Based Practice and Innovation

- Clinical Director, Business Manager, Research Officers, Health Economist plus in kind support
- Launched in October 2009
- Links with NICE, NHS Evidence, NTAC
- Will produce briefings and 'how to do it' guides then follow up to assess impact and better understand barriers to/issues around adoption



## NHS Constitution

- NHS commitment to the promotion and conduct of research
- The NHS will do all it can to ensure that patients are made aware of research that is of particular relevance to them

## NHS Operating Framework

- SHAs to ensure that NHS Trusts work with NIHR Clinical Research Network locally to contribute to national ambition to double the number of patients in clinical research
- All providers to increase their participation in research

## Duty to Promote Innovation

- SHAs to support NIHR Clinical Research Networks
- SHAs to develop the capacity of the NHS to support research

## Quality Accounts

- All providers to report on the number of patients in clinical research expressed also as a % of the total number of patients treated

# Statutory duty to promote the adoption and spread of innovation

- Assessing opportunities for innovation
- Supporting innovators
- Encouraging innovative partnerships and networks
- Rewarding innovation



# Innovation Review

- Innovation review set foundation for how we promote adoption and spread
- Key messages:
  - Foster a coalition of partners, including non NHS partners
  - Changing mindsets and culture is key
  - Building capability and capacity within the system



# East of England Innovation Council

- Wide span of partners – industry, academia, NHS, voluntary sector
- Work plan includes:
  - Advice on the award of regional innovation funds
  - Stimulating innovation through commissioning and procurement
  - Promoting leadership to develop innovative culture



# Three “big QIPP ideas” – urgent care, elective care and LTS – suggest an overall productivity improvement potential of £380-622m

	<u>Lever</u>	<u>Estimated potential</u>	
		£m	
<b>Urgent care</b>	•Up-coding (50%)	7-30	<b>66-124m</b>
	•Shift to lower cost setting (50%)	40-75	
	•Ambulance (100%)	19	
<b>Elective care</b>	•Up-coding (50%)	7-30	<b>93-211m</b>
	•Reduce diagnostic variation (100%)	5-11	
	•Reducing referrals (100%)	26-52	
	•Decommissioning ineffective procedures (100%)	15-43	
	•Shifting to lower cost setting (50%)	40-75	
<b>Long term conditions</b>	•LTC management	221-287	<b>221-287m</b>

# NHS East of England approach to innovation

❖ Alignment

**Regional  
Innovation Funds**

❖ Capacity and capability



Innovation Scouts



❖ Mainstreaming



**worldclasscommissioning**

❖ Encouraging new entrants



# Fostering an Innovative Culture

- Awards/prizes
- Case studies booklet
- Leadership and talent programmes



# Research and Innovation Strategy to deliver TtBT

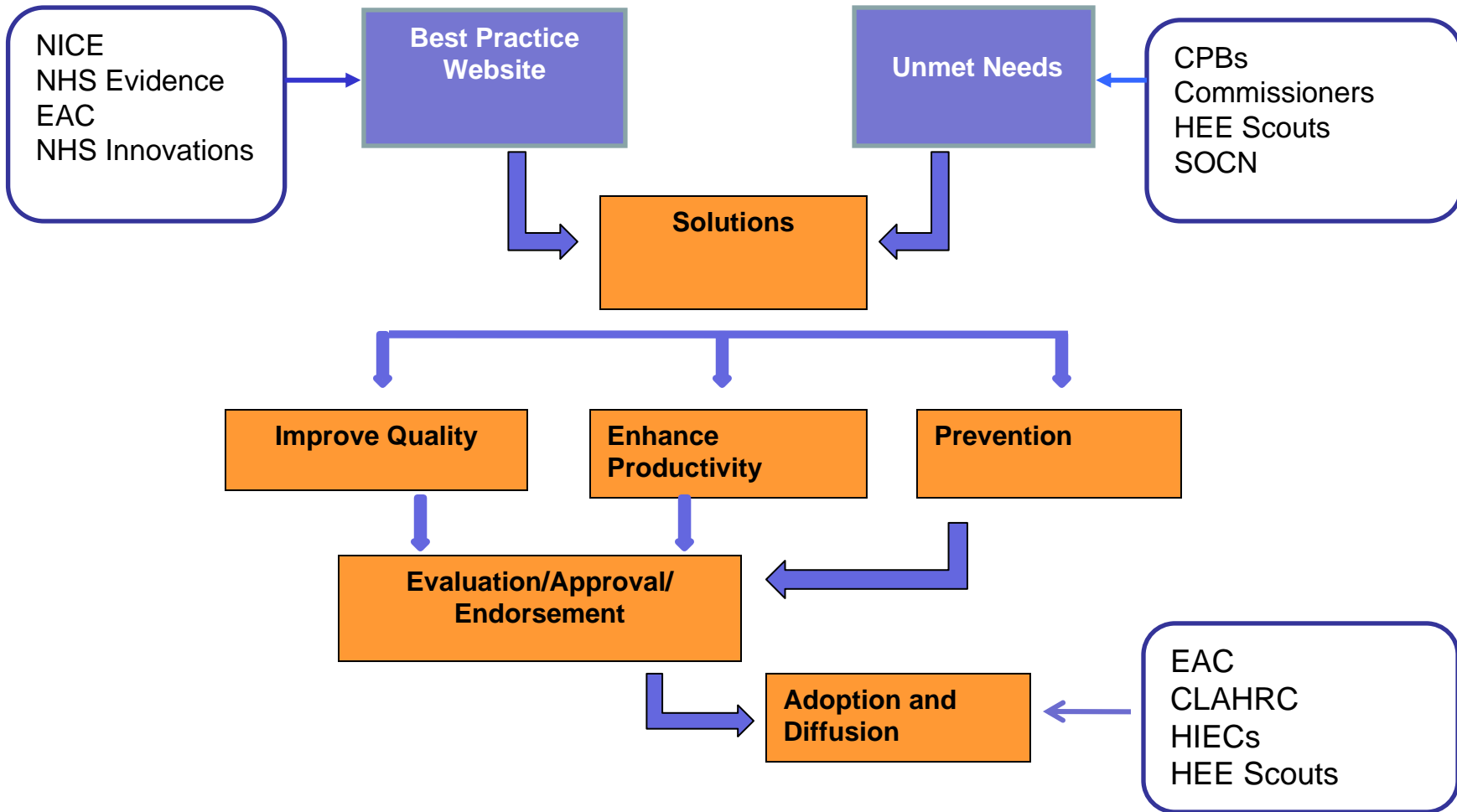

# Strategic Approach – Next Steps

- Ensuring research and innovation respond to NHS priorities
- Developing capacity through CAR, leadership programmes, supporting R&I infrastructure, increasing patients into trials
- Patient awareness of research – more work needed
- Supporting implementation and diffusion of research findings and innovations with CLAHRC, EAC and HIECs



# Strategic Approach - Benefits

- Improved understanding of partner agendas and expertise
- Combining resources to fund joint initiatives
- Coordinated response to national policies
- Create opportunities for locally driven needs to develop into research and innovation
- Benefits to patients through increase in evidence-based practice through adoption of new methods & technologies



Thank you for coming





*East of England*



*National Institute for  
Health Research*

Joint Health Research Conference:  
**Committed to better research in the NHS**

Friday 6 November 2009

Sopwell House, St Albans, Hertfordshire

